

pellon[®]

*The Magic
in the Middle*

Just Tri It! Quilt Skill Level: Beginner

Designed By
Lauren Dahl
Sewn By
Lauren Dahl

www.selvagedesigns.com



Thinking about sewing a quilt? Just Tri It! This quilt is fabulously modern, colorful, and most importantly, quick and easy to sew. Use this method for quickly cutting half square triangles in batches, and you will have a gorgeous quilt in no time. This method creates bias edges which may result in some stretch with the blocks. To alleviate this issue, try backing the 10" fabric squares with Pellon[®] SF101 Shape-Flex[®]. Legacy[™] by Pellon[®] White Cotton Batting is the perfect match for showing off the bright pops of white in this fun, geometric design. Sample used Pure Elements by Art Gallery in Snow, Ash, Lemonade, Verve Violet, Mirage Blue, Noir and Coral Reef. Finished quilt size is 65½" x 89½".

Fabrics Needed

Cotton fabric	1 yd each of six different colors
Backing and binding	5½ yds

Materials Needed

Pellon [®] SF101 Shape-Flex [®] (optional)*	10 yds
Legacy [™] by Pellon [®] White Cotton Batting	One twin size
Thread	

Tools Needed

Sewing machine and related supplies
Rotary cutter and related supplies
Basting pins

*SF101 Shape-Flex[®] is 100% cotton and will shrink similar to 100% cotton fabrics.

<http://www.pellonprojects.com>

Graphic Artist Alexandra Henry

PERMISSION IS GIVEN TO REPRODUCE FOR PERSONAL USE ONLY ©2014 - PCP Group, LLC

Assembly

Step 1. Cutting Instructions.

Six main fabrics Cut twelve 10" squares each
Shape-Flex® (optional) Cut seventy-two 10" squares

Step 2. If using Shape-Flex, place one square of Shape-Flex® on the wrong side of each fabric square. Fuse following manufacturer's instructions. This will stabilize the bias edge when the squares are cut in Step 8. Place the six stacks of 10" squares in a row.

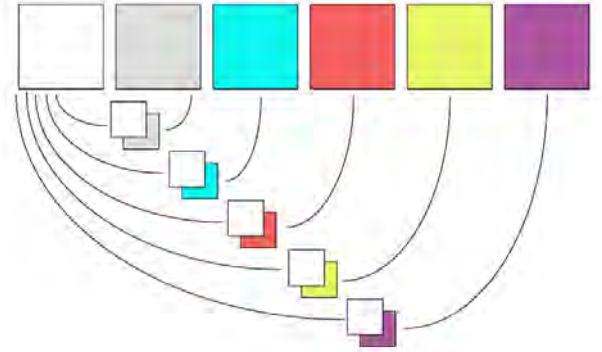

Step 3. Take one square from the first stack and place it right sides together with a square from the second stack. Start a new stack with the two squares.

Step 4. Take one square from the first stack and place it right sides together with a square from the third stack. Place these squares on top of the two squares from Step 3.

Step 5. Continue combining squares randomly working from left to right until all squares are in stacks of two.

Step 6. Take the top two squares from the stack. Stitch around the edges using a ¼" seam allowance. Set aside.

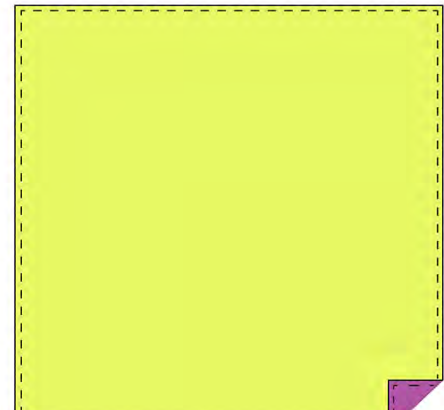

Step 7. Repeat Step 6 until all pairs of squares are sewn together.

Step 8. Using a rotary cutter and a ruler, cut each pair of squares on both diagonals to create four sets of Half Square Triangles. There will be 144 total Half Square Triangle units.

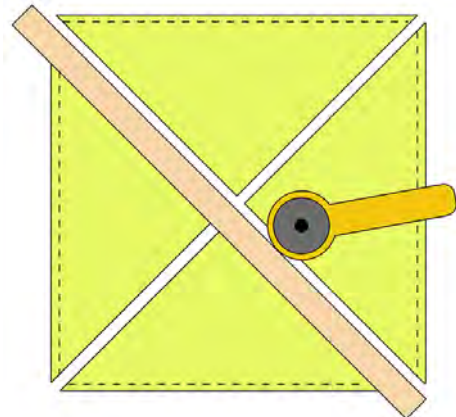

Step 9. Press seams to one side, ensuring the corners of each Half Square Triangle are pressed flat.

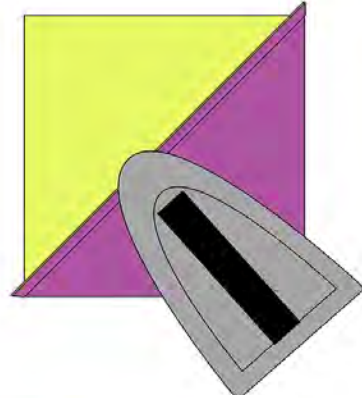

Step 10. Trim the corner points that extend beyond the pressed squares.

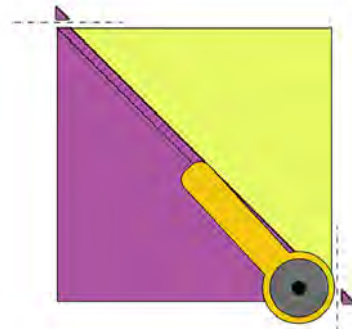

Step 11. Place the squares as desired into fourteen rows of ten squares each. There will be four squares left over.

Step 12. Sew the squares in each row together using a 1/4" seam allowance. Press the seams for the odd number rows to the right and the seams for the even number rows to the left.

Step 13. Sew the rows together using a 1/4" seam allowance. Press seams in one direction.

Step 14. Cut and piece backing to fit.

Step 15. Layer backing, batting and quilt top.

Step 16. Quilt as desired.

Step 17. Bind quilt.

