

pellon[®]

*The Magic
in the Middle*

Valentine Hearts Table Topper

A Foundation Pieced Design

Skill Level: Beginner

Designed By
Alexandra Henry
Sewn By
Alexandra Henry



<http://www.artbyalexa.com>

Use Pellon[®] Stitch-N-Tear Lite[™] to foundation piece the heart blocks. Run the Stitch-N-Tear Lite[™] through your ink jet printer to create the foundations for the blocks. Table runner is an octagon shape measuring 24-3/4" at its widest point. Sample used fabric by Kona Bay.

Fabrics Needed



Fabric A - Kona Bay BCAR-06 Red	3/8 yard
Fabric B - Kona Bay GT-0046-01 Red	3/8 yard
Fabric C - Kona Bay GT-0039 Coral Tree Fabrics, White on Cream	3/4 yard
Binding fabric	1/4 yard
Backing fabric	3/4 yard

Materials Needed

Pellon [®] 835 Stitch-N-Tear Lite [™]	One package
Pellon [®] 987F Fusible Fleece	3/4 yard
Thread	

Tools Needed

Sewing machine and related supplies
Rotary cutter and related supplies

<http://www.pellonprojects.com>

Graphic Artist Alexandra Henry

PERMISSION IS GIVEN TO REPRODUCE FOR PERSONAL USE ONLY ©2013 - PCP Group, LLC

Cutting Instructions

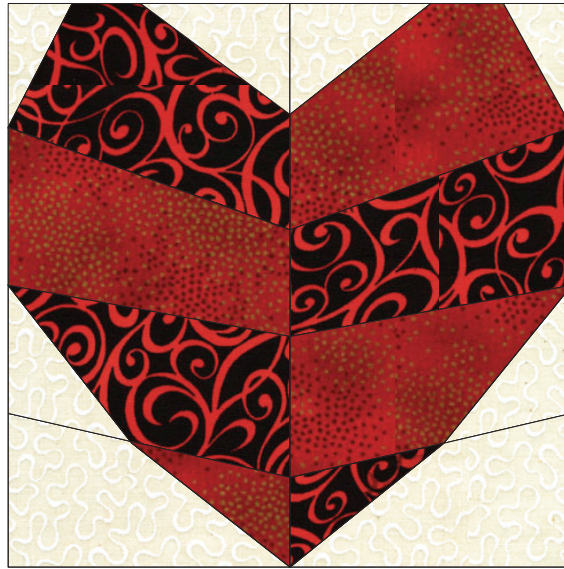

Cut the following (strips are cut across the full width of the fabric): Makes four 8-1/4" blocks

Fabric A	One 5-1/2" strip, one 6" strip
Fabric B	One 5-1/2" strip, one 6" strip
Fabric C	One 5" strip, two 4" strips, one 9-1/8" strip

Subcut each strip as follows:

Fabric A	Pieces A2 and D1 Piece B1 Piece F2	Cut eight 6" x 4" rectangles Cut four 5-1/2" x 3-1/2" rectangles Cut four 4" x 3" rectangles (from the 5-1/2" strip)
Fabric B	Pieces A1 and D2 Piece E1 Piece C2	Cut eight 6" x 4" rectangles Cut four 5-1/2" x 3-1/2" rectangles Cut four 4" x 3" rectangles (from the 5-1/2" strip)
Fabric C	Pieces C1 and F1 Pieces A3, B2, D3 and E2 Pieces A4 and D4 Setting triangles Center square	Cut eight 5" x 3-1/4" rectangles Cut sixteen 4" x 3" rectangles Cut eight 3-1/4" x 3-1/2" (from one 4" strip) Cut two 9-1/8" square Cut one 8-1/4" square (from the 9-1/8" strip)

Refer to foundation piecing layouts on pages 11 and 12. Separate all the pieces by piece letter/number. Mark the piles to make piecing easier.

Assembly Instructions

Set stitching length to 1.5 for all foundation stitching.

Cut the Stitch-N-Tear Lite™ into 8-1/2" pieces across the width of the roll. Eight pieces are needed for the four blocks. Press the Stitch-N-Tear Lite 8-1/2" x 12" rectangles until they lay completely flat.

Print one sheet at a time. Decide if the foundation templates will be torn out or left in. Use the lettered templates if foundations will be torn out. Use the unlettered templates if foundations will be left in. Sample photos show foundation lettered templates. Print four copies of each of the two template pages with or without lettering. Make sure the printer is printing at 100%. Check gauge.

Cut the foundation sections apart. Cut outside the dashed lines. There will be extra foundation around the dashed lines for each section.

Place section A foundation face down. Center the piece A1 6" x 4" rectangle right side up over the A1 place on the foundation, extending over the line between A1 and A2 1/4". Pin in place.

Place the piece A2 6" x 4" rectangle right sides together with the A1 piece, aligning the raw edges as shown. Pin in place

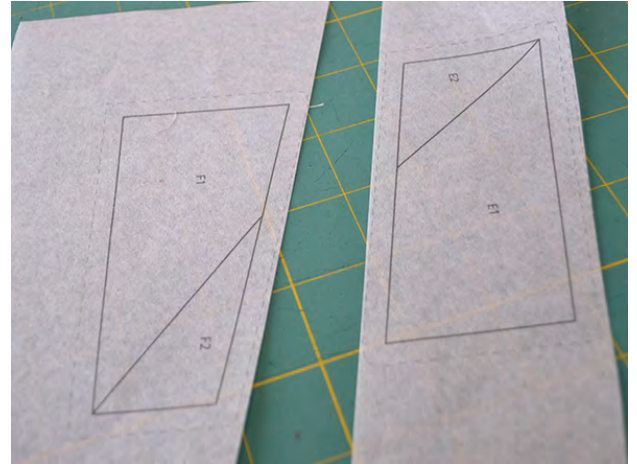

Turn the foundation over so the right side of the foundation is facing up. Stitch the seam between piece A1 and A2 on the line, backstitching at the start and the stop points.

Open up the A2 piece and press.

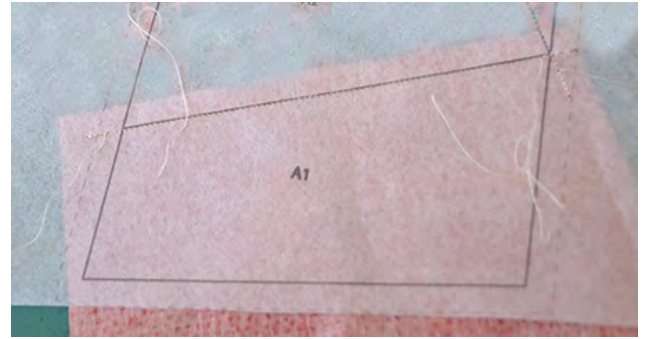

Fold back the foundation only along the seam between A2 and A3 as shown. Place a ruler 1/4" over the seam line. Trim the seam allowance of piece A2 to 1/4".

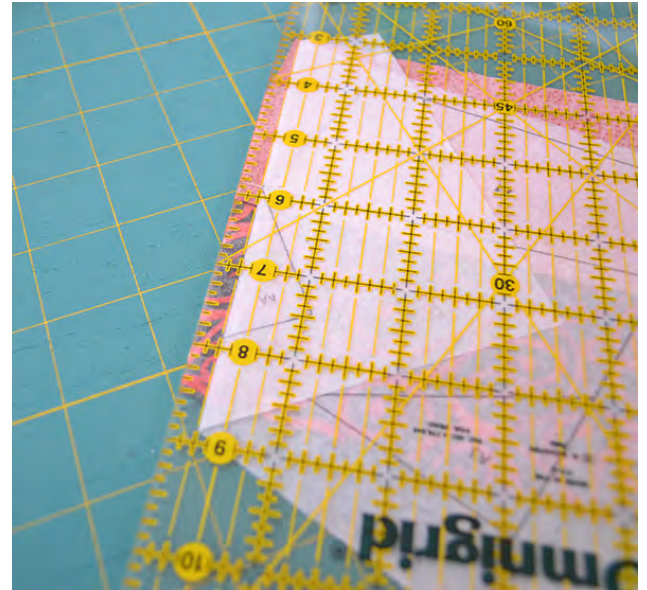

Place the piece A3 4" x 3" rectangle right sides together 1/4" over the seamline between A2 and A3, aligning raw edges. Pin in place.

Stitch and press as in the previous steps.

Repeat these steps with the piece A4 3-1/4" x 2-1/2" rectangle.



Turn the section so the foundation right side is facing up.

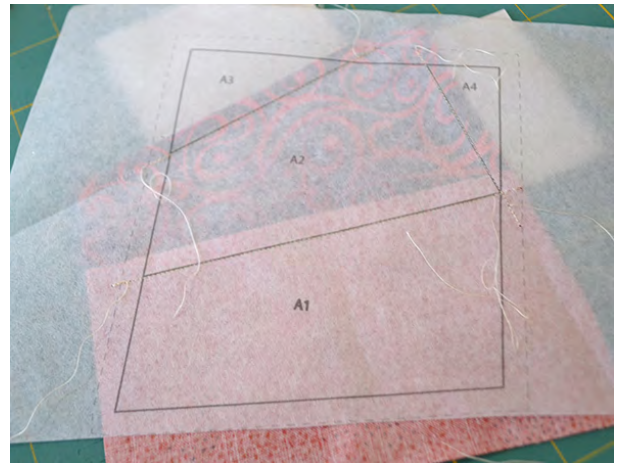

Trim the section on the outside dashed line (1/4" overall seam allowance line).

Make three more section As.

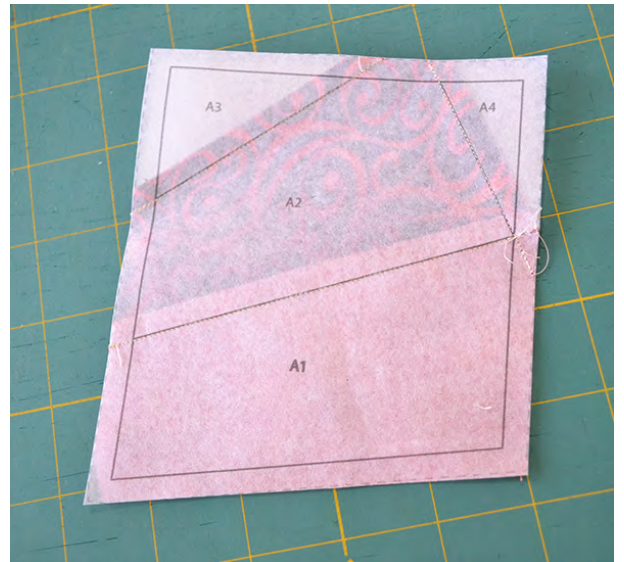

Set the four finished section As aside.



Repeat these steps for the remaining sections.

NOTE: Section D is identical to Section A. For sections B, C, E and F, after placing the first piece and pinning in place, turn the section so the foundation is facing right side up. Fold back the foundation on the seam line between the pieces. Place a ruler 1/4" over the seam line and trim the first piece 1/4" from the seam line as shown. Open the foundation template. Place the second piece as done in previous steps and continue stitching.

Make four of each section.

Pin the sections right sides together following the layout below. Align the seam line to be stitched for both sections. Stitch seam line, backstitching at the start and the stop.

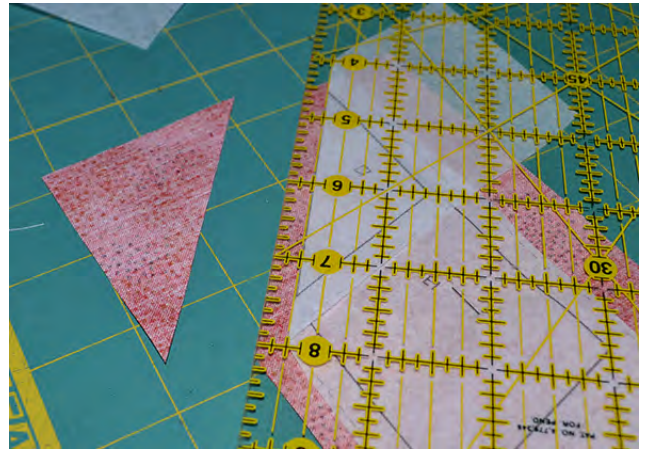
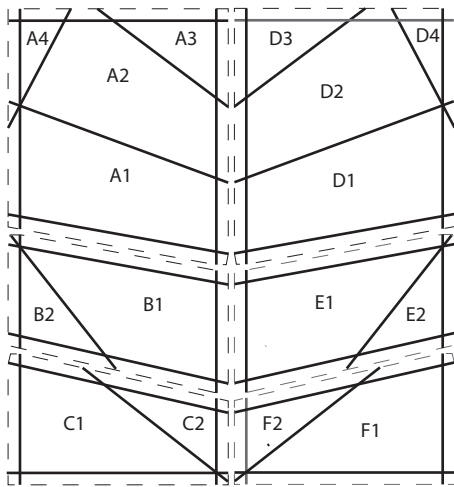

Press seams for the left side of the heart towards the bottom and the seams for the right side of the heart towards the top.



Place two halves of a heart block right sides together, aligning the seam lines. Stitch along the seam line, backstitching at the start and stop. Press seams open. Repeat this step for the remaining three heart blocks.



Cut the two 9-1/8" squares in half diagonally. Sew one triangle on each side of two of the heart blocks as shown using a 1/4" seam allowance. Press seams towards the triangles.



Sew one heart to each side of the 8-3/4" center square as shown. Press seams towards the center square.



Sew the rows together as shown using a 1/4" seam allowance. Press seams open.

Cut one 26" square of background fabric. Cut one 26" square of Fusible Fleece. Fuse the Fusible Fleece to the wrong side of the background square following manufacturer's instructions.

Place the wrong side of the table topper on the Fusible Fleece. Pin all three layers together.

Quilt as desired.

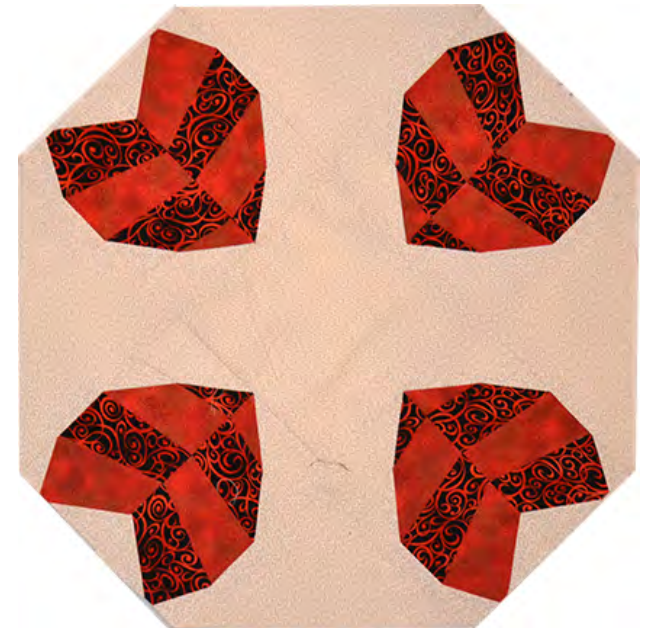

Cut three 2-1/4" strips from the binding fabric. Place one binding strip perpendicularly on one other binding strip as shown. Sew on a diagonal to connect the two pieces as shown. Trim seam allowance to 1/4".

Repeat this step to connect the third binding strip.

Fold the binding in half lengthwise, wrong sides together.



On the corner points of the table topper, place a mark where the seam allowance from both sides of the point cross each other (1/4" in from each edge.) Leaving an 8" tail, place the raw edges of the binding on the raw edge of the topper, approximately 2" from one of the corner points. Place a pin through the binding into the mark on the corner. Stitch using a 1/4" seam allowance to that point. Stop with the needle facing down.

Raise the presser foot and turn the topper so that the corner point is facing towards the back. Reverse stitching and stitch backwards to the point. Remove topper from the machine.

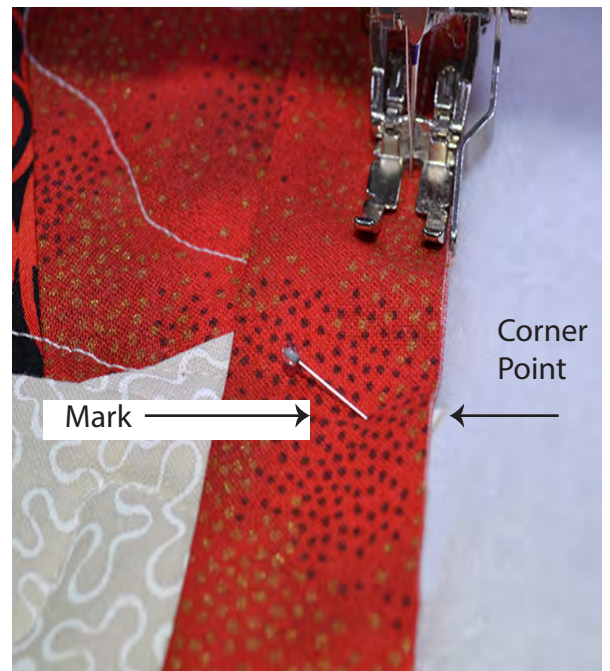

Fold the binding up to the stitched line. The raw edges of the binding will be in a line with the raw edge of the topper as shown.

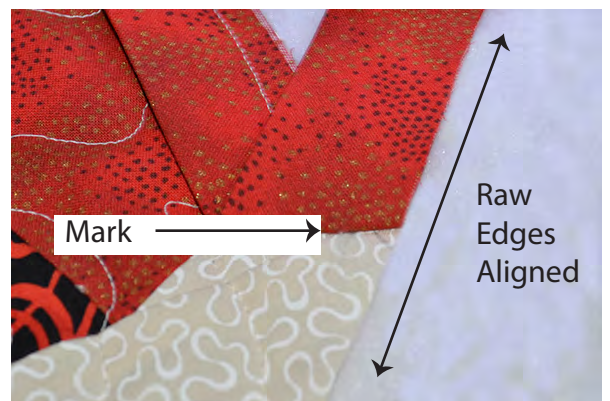

Fold the binding back down to to the next side. The line of the fold will be exactly 90° perpendicular to the next side. The top of the fold will line up with the point of the topper.

Starting at the folded edge, continue stitching the binding down.

Repeat these steps at each corner point. Stop stitching 2" past the last corner.

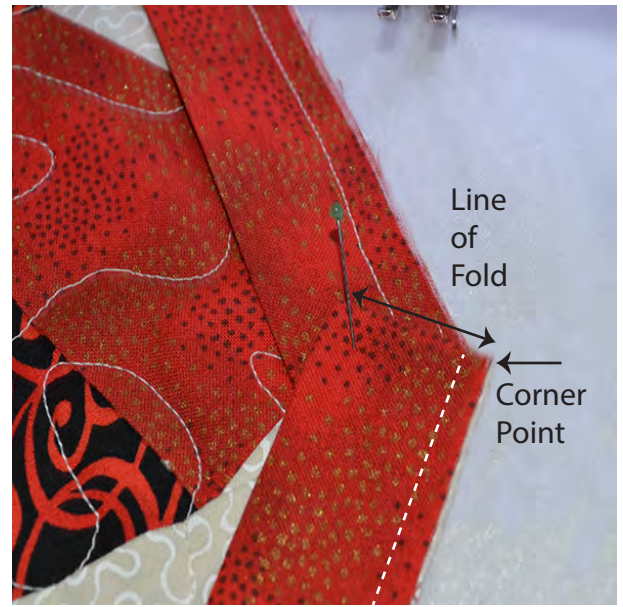

Fold the binding ends so that the two folds are exactly 1/4" apart as shown. Make a crease in the fold.



Open one of the binding ends and make a plus sign in the crease. Line up a ruler with the 45° line along the edge of binding through the center of the plus sign. Draw a line as shown.

Repeat this step with the other binding end.



Cut the binding strips 1/4" past the drawn line.

Place the two binding strips right sides together, matching the drawn line. Since this binding is so short, it is recommended to hand stitch the two pieces together using a short running stitch.

Refold the binding and place it against the raw edge of the topper. Stitch the rest of the binding down.

Fold the binding to the back and hand stitch down, mitering each corner as it is reached.



Heart Template Left Side

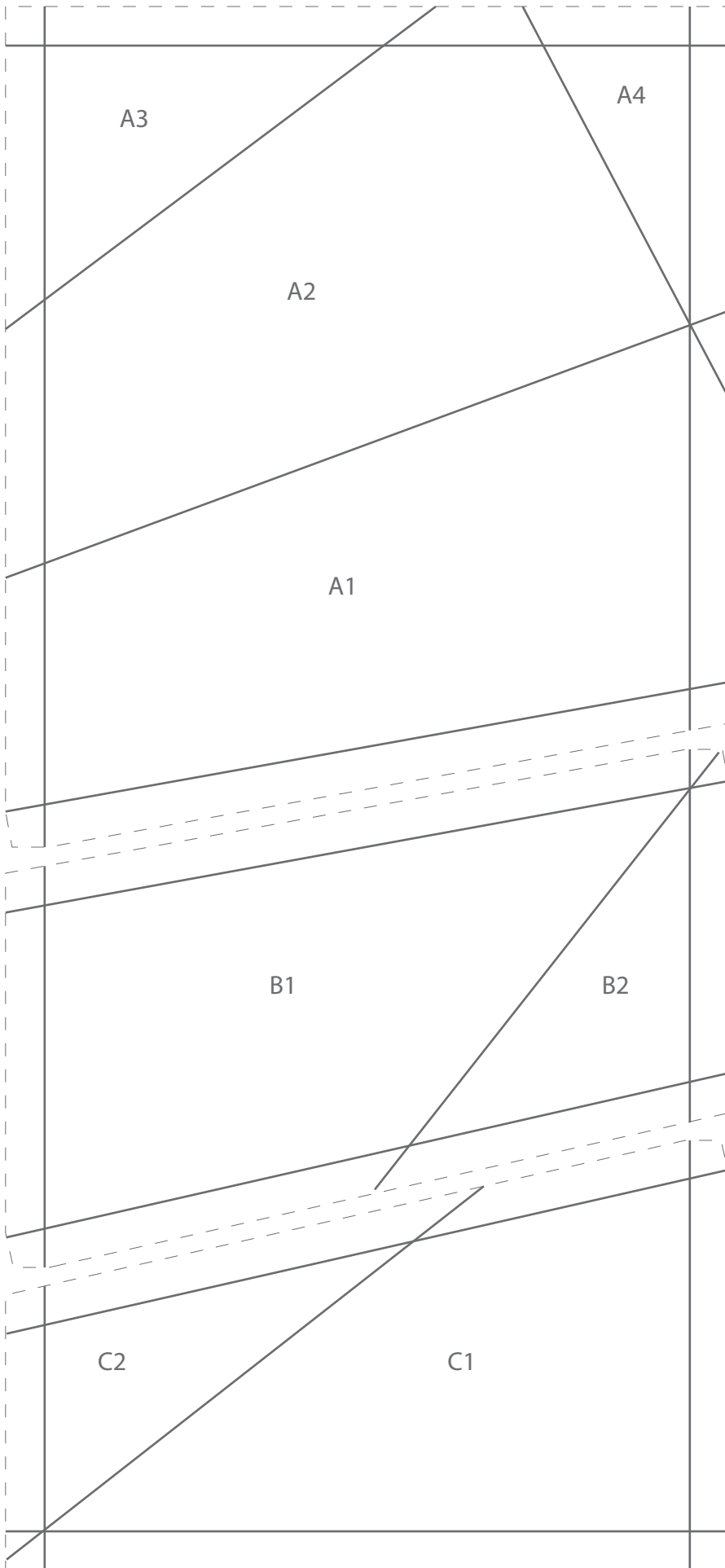

Use this set of foundations if foundation will be torn away. Use the unlettered foundation templates if foundation will be left in the table topper. Cut the Stitch-N-Tear Lite™ into 8-1/2" sheets. Press flat with iron. Set printer to 100%. Check gauge. Print four of each template.

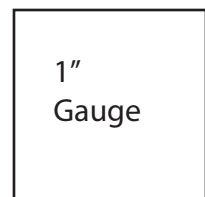

Heart Template Right Side

Use this set of foundations if foundation will be torn away. Use the unlettered foundation templates if foundation will be left in the table topper. Cut the Stitch-N-Tear Lite™ into 8-1/2" sheets. Press flat with iron. Set printer to 100%. Check gauge. Print four of each template.

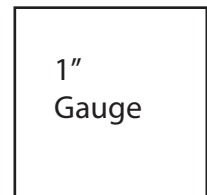
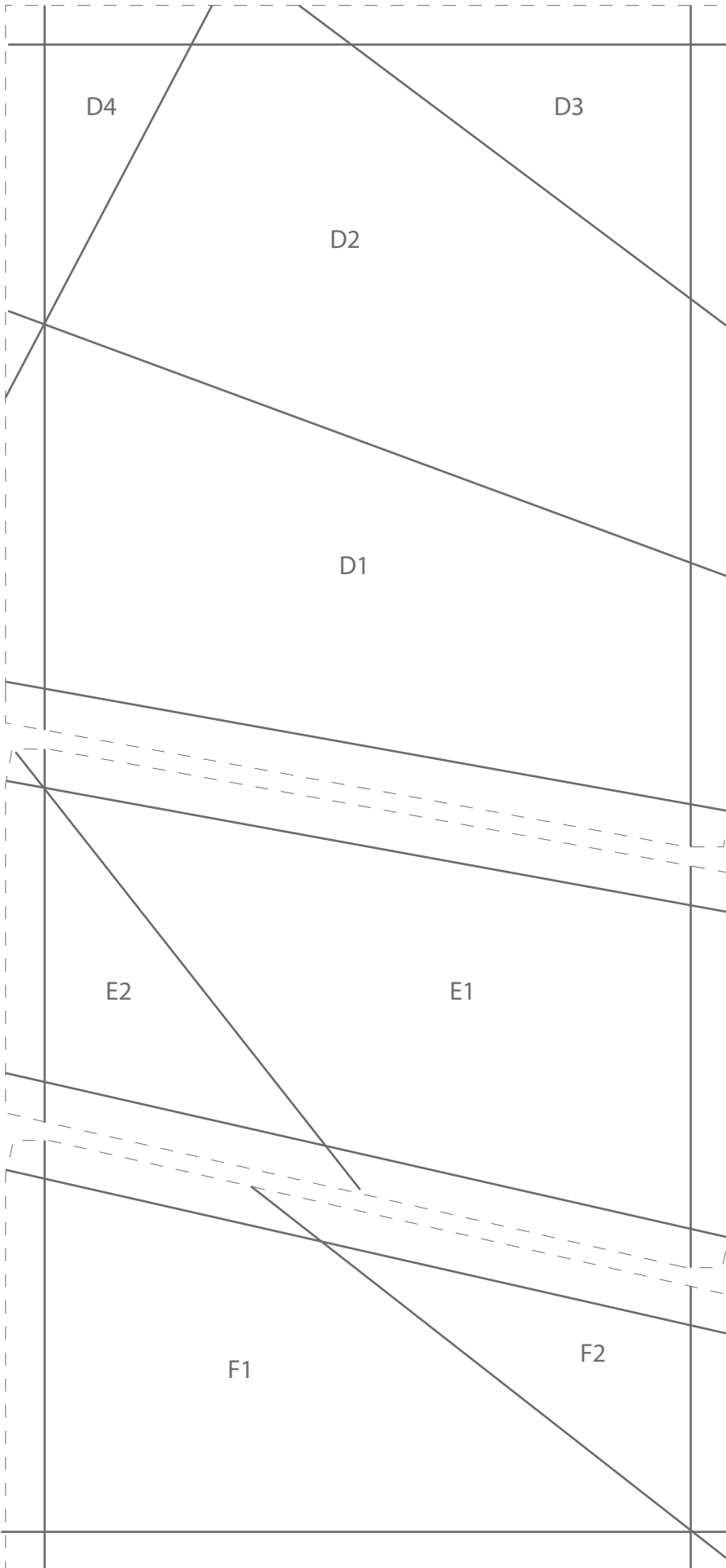

Heart Template Left Side

Use this set of foundations if foundation will be torn away. Use the unlettered foundation templates if foundation will be left in the table topper. Cut the Stitch-N-Tear Lite™ into 8-1/2" sheets. Press flat with iron. Set printer to 100%. Check gauge. Print four of each template.

NOTE: Use the * symbol to aid in placing the templates face down for placing pieces.

See lettered templates for reference.

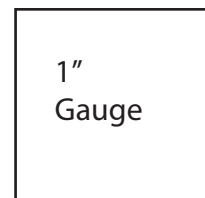
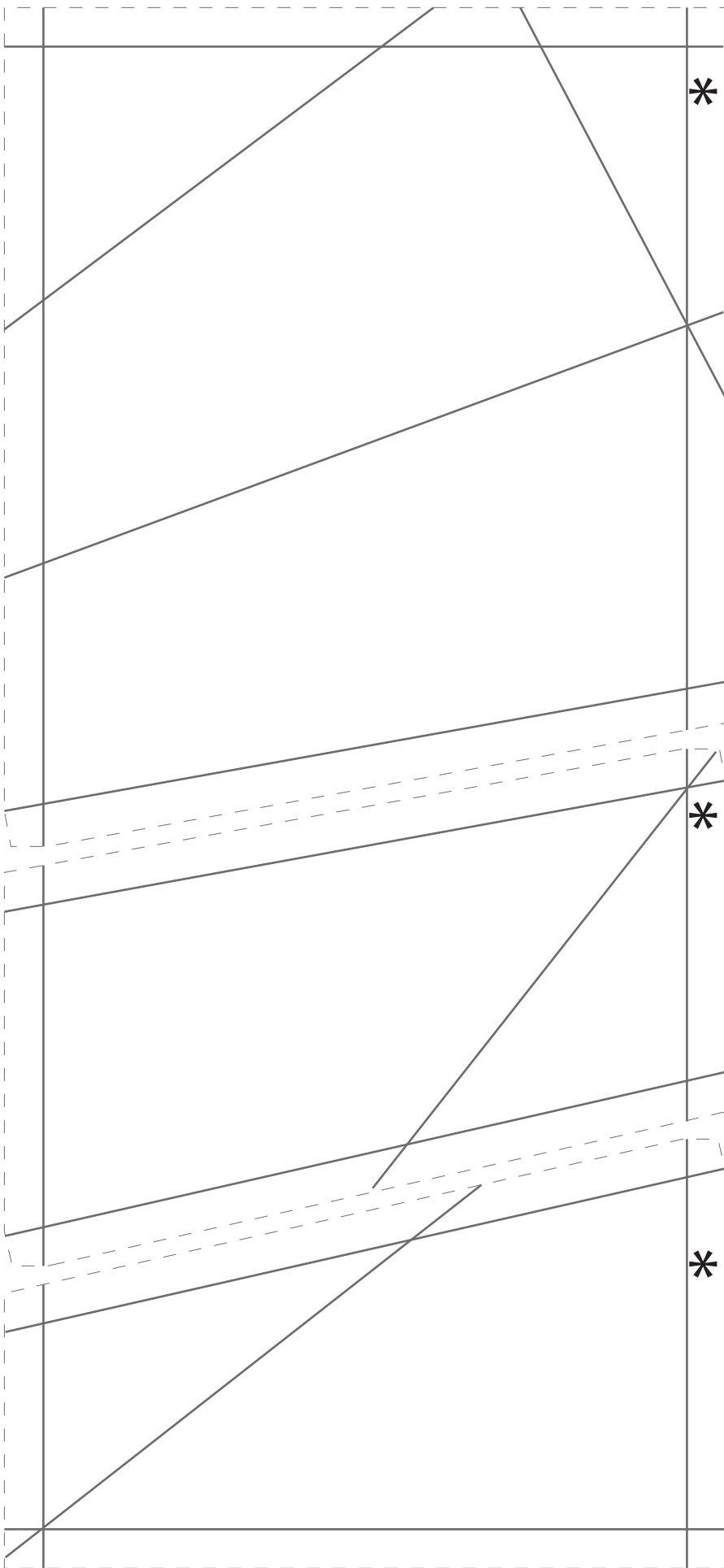

Heart Template Right Side

Use this set of foundations if foundation will be torn away. Use the unlettered foundation templates if foundation will be left in the table topper. Cut the Stitch-N-Tear Lite™ into 8-1/2" sheets. Press flat with iron. Set printer to 100%. Check gauge. Print four of each template.

NOTE: Use the * symbol to aid in placing the templates face down for placing pieces.

See lettered templates for reference.

